

**AMAJUBA DISTRICT MUNICIPALITY
INVITATION TO BID**

BID No.: T2016/13

**SUPPLY AND ERECTION OF SECURITY FENCING IN KWAPOLITENI WATER POINT,
DANNHAUSER CBD RESERVOIR AND INVERNESS WATER POINT**

Bidders registered on the Central Supplier Database are hereby invited for the supply and erection of security fencing in Kwapoliteni Water Point, Dannhauser CBD Reservoir and Inverness Water Point. Bidders must comply with CKS82, SABS763, and SABS 675 standards.

Bidders must be registered with CIDB grading of 2SQ or higher class of construction works. **This bid will be evaluated in terms of 80/20 preference point system as prescribed in Amajuba District Municipality Supply Chain Management Policy.**

NB: Bidders are required to submit original valid B-BBEE Status Level Verification Certificates or certified copies thereof together with their bids, and sworn affidavits to substantiate their B-BBEE rating claims. Failure to submit the B-BBEE Certificate/ sworn affidavits will result in forfeiting the points

Bid documents are obtainable from the Amajuba District Municipality offices during normal working hours, B9356 Section 1, Madadeni, 2951; or can be downloaded from the website www.amajuba.gov.za.

Completed BID documents including all returnable documents in sealed envelopes endorsed "**BID NO. T2016/13 "SUPPLY AND ERECTION OF SECURITY FENCING"**" must be deposited in the municipality's tender box located at the Reception of Amajuba District Municipality, B9356 Main Street, Section 1, Madadeni, 2951; after which all bids received will be opened in public. No late bids submitted after the closing date and time will be accepted. The Amajuba DM reserve the right not to award/appoint the lowest or any bid.

For bidding enquiries kindly contact **Mrs Nokwazi Nzimande** of the SCM Unit on (034)3297200 or by email nokwazin@amajuba.gov.za, and for technical enquiries kindly contact **Mr Mthembeni Jiyane** on (034)329 7200 or by email mthembenij@amajuba.gov.za

.....
Closing date: Friday, 30 September 2016 @12h00 noon



**MR U AFRICA
MUNICIPAL MANAGER**





TERMS OF REFERENCE

SUPPLY AND ERECT SECURITY FENCING IN KWA POLITENI WATER POINT, DANNHAUSER CBD RESERVOIR AND INVERNESS WATER POINT.

1. BACKGROUND

All Water storages need to be secured at all times to avoid risk of water contamination. It is to ensure that we supply safe drinking water to our communities.

Coordinates

Inverness Water point S27 53 18,43 and E30 087 47,84

Kwapoliteni S27 57 05,91 and E30 09 27,83

Danhauser CBD S28 00 00,17 and E30 03 12,40

2. SCOPE OF WORK

This specification covers the construction of security fencing and gates around the concrete reservoir. The contractor is expected to supply and erect diamond wire razor mesh, supply and erects straining posts for fence, supply and erects double leaf gates and pole concrete beam at base of fence.

2.1.2 MATERIALS

2.1.2.1 Posts, Stays and Standards

Post, stays and standards shall be of the type and size indicated on the drawings. Steel sections shall comply with the requirements of CKS 82.

Tubular posts shall be 100 mm diameter mild steel and galvanized in accordance with SABS 763 for class B1 articles and have a wall thickness of 2.25mm minimum.

Hole spacing shall be 200 mm. The bottom hole shall be 50 mm above ground level. Unless otherwise shown on the drawings all tubular sections shall be provided with a 200mm x 200mm footplate and a pressed steel cap.

Tubular stays shall have a nominal bore of at least 50mm and a minimum wall thickness of 2.95 mm and be galvanized as specified above.

2.1.2.2 Bolts for Stays.

Bolts shall be galvanized steel bolts of the required length and diameter which shall not be less than 12mm. All the necessary bolts, together with nuts and washers, shall be supplied with each post.

2.1.2.3 Wire.

Smooth Wire

Smooth wire shall comply with the requirements of SABS 675 and shall be of the types specified below. Straining wire shall be 3.15mm diameter lightly galvanized wire. Tying wire shall be 2.50 mm diameter mild steel lightly galvanized wire for tying razor cut barbed wire to standards.

Diamond Shaped Razor Mesh for security fence.

Diamond shaped Razor Mesh shall be welded and galvanized. Aperture size shall be 150 mm x 300 mm. The nominal diameter of the wire shall be 2.5 mm with long bladed super bards 19 mm wide and 23.5 mm long.

2.1.2.4 Gates

Gates shall be manufactured to the dimensions shown on the drawings. Gates shall be complete in every respect including hinges, washers, bolts and locking chain attached to the gate and diamond shaped Razor Mesh in the case of security gates.

2.1.3 CONSTRUCTION

2.1.3.1 Installing Straining Posts and Intermediate Posts.

Straining posts shall be erected at all ends, corners and bends in the line of fences and at all junctions with other fences.

Straining posts shall not be spaced further apart than shown on the drawings. The length of post above the ground shall be such that the correct clearance between the lowest wire and the ground can be obtained.

Posts shall be accurately set in holes and where shown on the drawings provided with concrete bases to the dimensions shown on the drawings.

Holes shall be dug to the full specified depth of the posts.

Corner, gate end and straining posts shall be braced by means of stays or anchors as shown on the drawings. Pipe stays shall be bolted to the posts.

Standards shall be firmly planted into the ground at the spacing shown on the drawings. The spacing of standards between any two straining posts shall be uniform and not greater than shown on the drawings.

All posts and standards shall be accurately aligned and set plumb.

2.1.3.2 Installing Wire

All fencing wire shall be wired to the sides of standards or posts to prevent the wires from being displaced or becoming loose. The wire shall be carefully stretched and hung without sag, and with true alignment, care being exercised not to stretch the wire so tightly that it will break, that end, corner, straining or gate posts will be pulled up, or that it will be easily damaged during veld fires.

Each strand of barbed wire shall be securely fastened in the correct position to each standard with soft galvanized binding wire.

The binding wire for each horizontal barbed wire shall pass through a hole or notch in the standard to prevent slipping of the fence wire in a vertical direction, while the ends of the wire shall be wound at least four times around the fencing wire to prevent it moving in a vertical direction.

At end corner, straining and gate posts the barbed wire shall be securely wrapped around the post and secured against slipping by tying the end tightly around the wire by means of at least six snug tight twists.

In the case of high tensile wire, two long windings may first be made before the six tight twists, to prevent the wire from breaking at the first twist.

When using smooth wire the loose end shall preferably be bent over and hooked into the notch between the fencing wire and the first windings.

Splices in the fencing wire shall be permitted if made in the following manner using a splice tool. The end of each wire at the splice shall be carried at least 75 mm past the splice tool and wrapped snugly around the other wire for not less than six complete turns, the two separate wire ends being turned in opposite directions. After the splice tool is removed the space left by it in the splice wire shall be closed by pulling the wire ends together. The unused ends of wire shall be cut so as to leave a neat splice.

2.1.3.3 Installing Diamond Razor Mesh for security fence.

Security fences of diamond mesh shall be stretched against the fence and properly tied to the fencing wire as shown on the drawings.

The diamond mesh shall be secured by means of soft binding wire at 1.2 m centers along the top and bottom wires and at 3 m centers along each of the other fencing wires unless otherwise shown on the drawings.

2.1.3.4 Installing Gates.

Gates shall be installed at the position indicated on the drawings. The gates shall be hung on gate fittings in accordance with the requirements shown on the drawings.

Gates shall be so erected as to swing in a horizontal plan and at right angles to the gate posts. The double swing gates shall not have a gap of more than 25 mm between them when closed.

2.1.4 TOLERANCES

2.1.4.1 General Requirements

The completed fence shall be plumb, taut, true to line and ground contour, with all posts, standards and stays firmly set.

The height of the lower fencing wire above the ground at posts and standards shall not vary from that shown on the drawings by more than 25 mm.

Other fencing wires shall not vary by more than 10 mm from their prescribed relative vertical positions.

2.1.4.2 Manufacturing Tolerances for Wire.

The actual diameter of the wire supplied shall nowhere be less than the specified diameters by more than the following tolerances.

SPECIFIED DIAMETER	TOLERANCE
1.0-1.8 mm	0.05 mm
2.0-2.8 mm	0.08 mm
3.15-4.0 mm	0.10 mm

2.1.5 MEASUREMENT AND PAYMENT

2.1.5.1 Security Fencing

Supply and erect Diamond shaped razor mesh fencing.....Unit

The rate tendered for the supply and erection of smooth wire strands at 200 mm spacing, the razor cut diamond mesh, and tying wire and all EPWP labour required.

2.1.5.2 Intermediate and Straining Posts

A) Supply and erect intermediate and straining post for security fencing.....Unit: No

Separate items are scheduled for intermediate and straining posts. Gate posts shall be measured and paid for as straining posts.

The rate tendered for the supply and erection of posts shall include for the supply of posts complete with footplate and pressed steel cap, stays and bolts. The rate shall also include all EPWP labour to excavate in all classes of material, backfilling and compaction with soil and with 15 MPa/38 mm all as shown on the drawings.

2.1.5.3 Gates

(a) Supply and erect double leaf gates complete for security fence. (4 m wide opening).....Unit: No

The rate tendered for the supply and erection of gates shall include the supply and erection of the gate complete with hinges, washers, bolts and locking chain, barbed, smooth and tying wire and diamond mesh.

(b)Excavate for and place 150 mm x 300 mm Concrete beam at base of security fencing as per drawing using 20 MPa concrete and using EPWP labours(including formwork).....Unit: Cubic meter's

3. REQUIREMENTS.

The bidder is expected to submit the following:

-Certified copies of Business registration Certificate.

4. GENERAL CONDITIONS OF CONTRACT

- A) This Contract will be based on the "General Conditions of Contract for Construction Works - 1st Edition 2004", issued by the South African Institution of Civil Engineering. (Short title: "General Conditions of Contract 2004").
- B) The District Municipality shall give thirty (30) days' notice for the termination of service.
- C) The Duration of contract is four months.
- D) Bidders must complete all items in schedule of quantities.

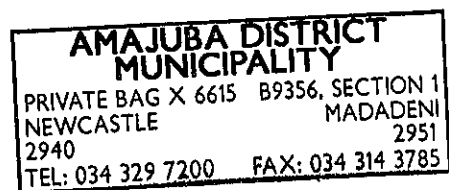

SCHEDULE OF QUANTITIES

ITEM NO	STARNDARD	DISCRIPTION	UNIT	QTY	RATE	AMOUNT	
						R	C
1.	SANS 1200A PSA 8.3	PRELIMINARY GENERAL FIXED-CHARGE ITEMS Contractual Requirements Establishment on the sites	Sum				
1.1.	PARTIC SPEC PSS	SECURITY FENCING					
2.	PSS 5.1	Supply and erect diamond shaped razor mesh security fencing	M	600			
	PSS 5.2	Supply and erect intermediate posts for security	No	300			
	PSS 5.3	Supply and erect straining posts for security fencing	No	150			
	PSS 5.4	Supply and erect double leaf gates complete for security fencing	No	6			
	PSS 5.5	150 mm x 300 mm 20 MPA concrete beam at base of fence	M3	600			

**AMAJUBA DISTRICT
MUNICIPALITY**
PRIVATE BAG X 6615 B9356, SECTION 1
NEWCASTLE MADADENI
2940 2951
TEL: 034 329 7200 FAX: 034 314 3785

SECTION	DESCRIPTION	AMOUNT (RAND)	
1.	Fixed-Charge Items.		
2.	Security Fencing		
	Subtotal		
	Contingencies 5%		
	Plus 14% VAT		
	TOTAL		

**AMAJUBA DISTRICT
MUNICIPALITY**

PRIVATE BAG X 6615 B9356, SECTION
NEWCASTLE MADALA
2940 2

TEL: 034 329 7200 FAX: 034 314 3700

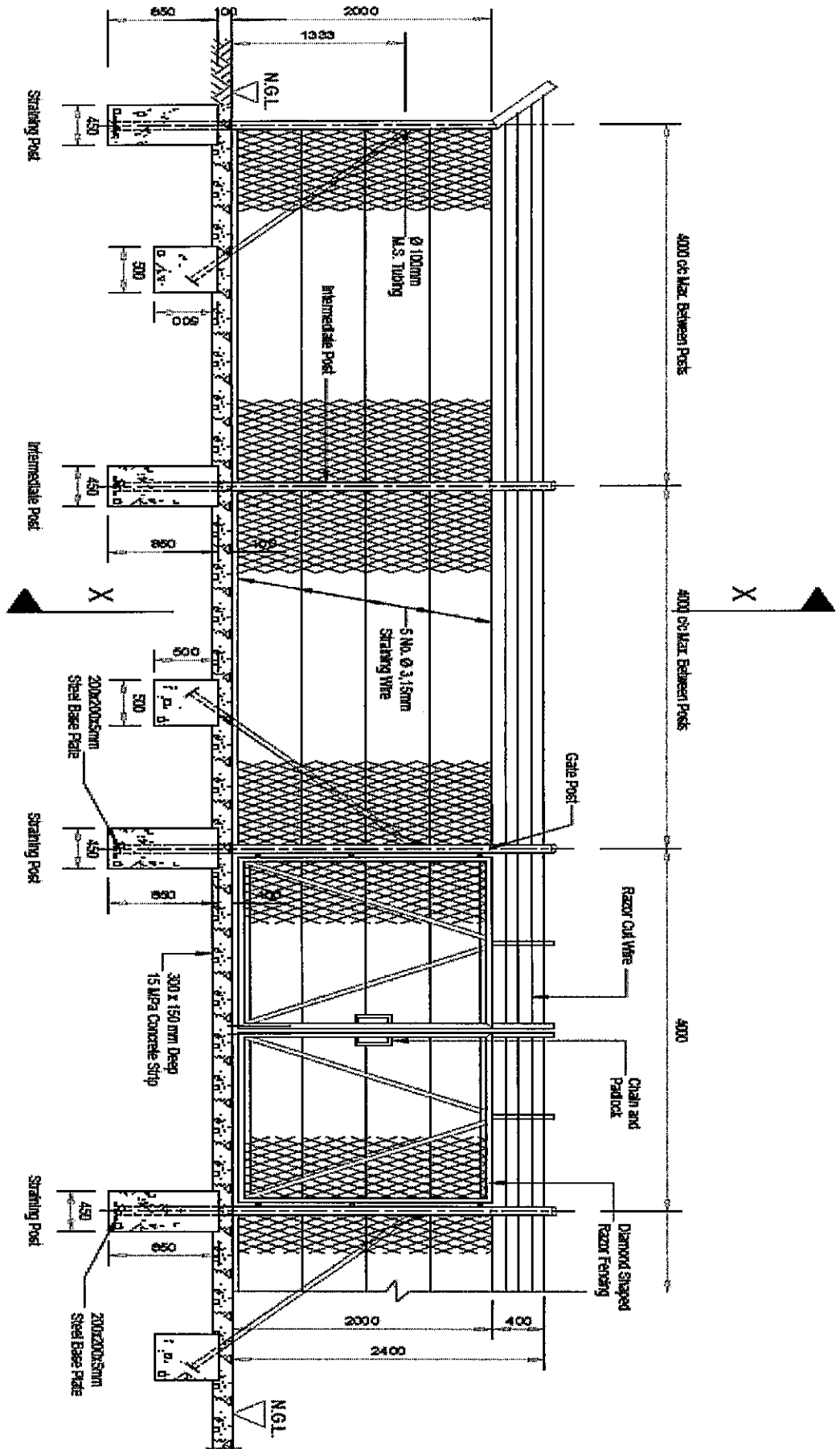

NOTE: All mild steel Posts are to be Galvanised tubing

GATE DETAIL

AMAJUBA DISTRICT MUNICIPALITY
 PRIVATE BAG X 6615 B9356, SEC
 NEWCASTLE MADABALA
 2940 25
 TEL: 034 329 7200 FAX: 034 314 37

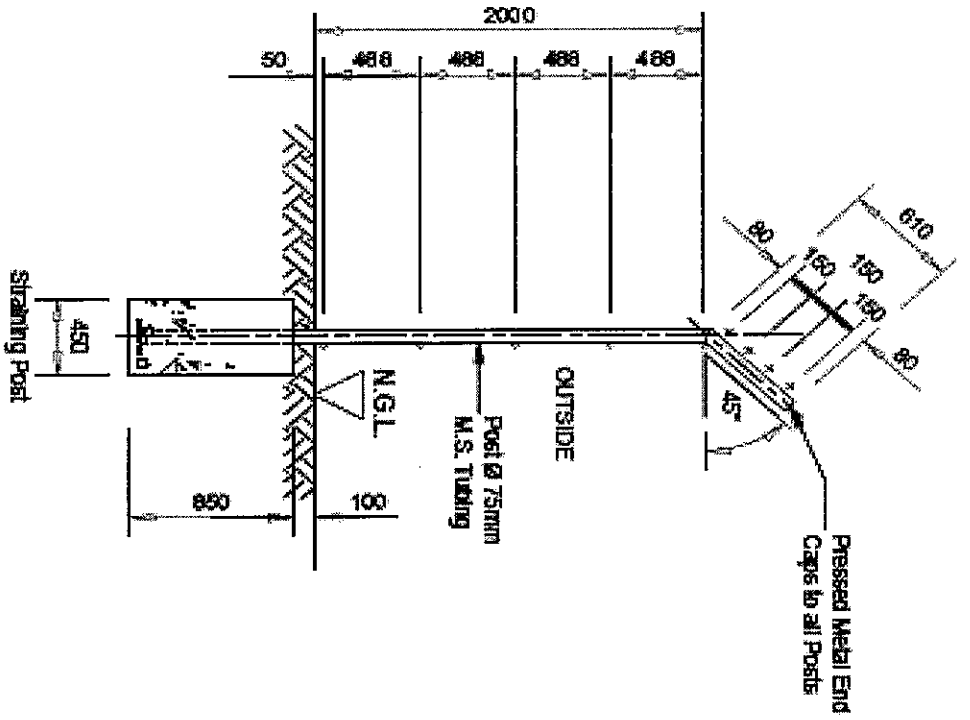

TYPICAL INTERMEDIATE POST

Scale 1:50

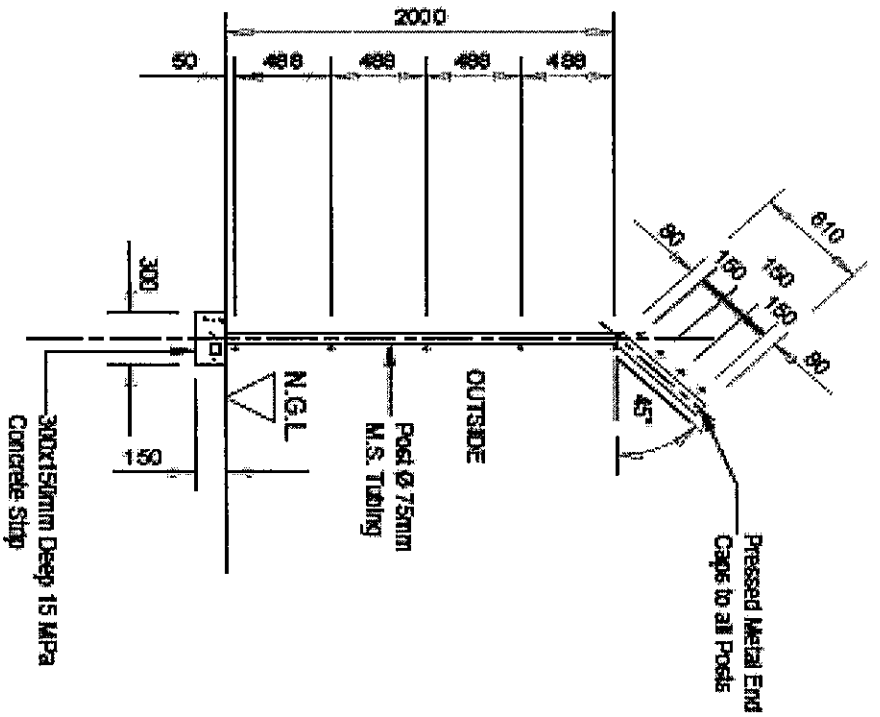

SECTION X-X

Scale 1:50

AMAJUBA DISTRICT MUNICIPALITY
 PRIVATE BAG X 6615 B9356, SECTION 40
 EWCASTLE M-District
 EL: 034 329 7200 FAX: 034 319

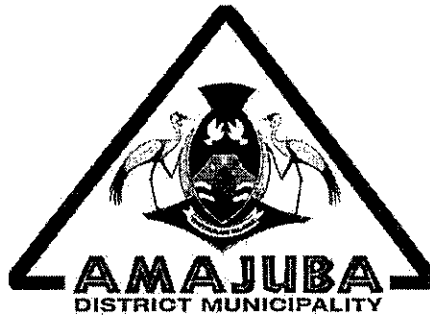

MBD 1

INVITATION TO BID

YOU ARE HEREBY INVITED TO BID FOR REQUIREMENTS OF THE AMAJUBA DISTRICT MUNICIPALITY

BID NUMBER: T2016/13

CLOSING DATE: 30 SEPTEMBER 2016

CLOSING TIME: 12H00

DESCRIPTION: SUPPLY AND ERECTION OF SECURITY FENCING

The successful bidder will be required to fill in and sign a written Contract Form (MBD 7).

BID DOCUMENTS MUST BE DEPOSTED IN THE TENDER BOX SITUATED AT:

The Reception
B 9356 Amajuba Building,
Section 1
Madadeni

Bidders should ensure that bids are delivered timeously to the correct address. If the bid is late, it will not be accepted for consideration.

The bid box is generally open from 07h30 to 16h15 during working hours and between 07h30 and 15h00 on Fridays

ALL BIDS MUST BE SUBMITTED ON THE OFFICIAL FORMS – (NOT TO BE RE-TYPED)

THIS BID IS SUBJECT TO THE GENERAL CONDITIONS OF CONTRACT (GCC) AND, IF APPLICABLE, ANY OTHER SPECIAL CONDITIONS OF CONTRACT

THIS BID WILL BE EVALUATED AND ADJUDICATED ACCORDING TO THE FOLLOWING CRITERIA:

1. Relevant specifications
2. Value for money
3. Capability to execute the contract
4. PPPFA & associated regulations

NB: NO BIDS WILL BE CONSIDERED FROM PERSONS IN THE SERVICE OF THE STATE (see definition on MBD 4 attached)

**THE FOLLOWING PARTICULARS MUST BE FURNISHED
(FAILURE TO DO SO MAY RESULT IN YOUR BID BEING DISQUALIFIED)**

NAME OF BIDDER

POSTAL ADDRESS

STREET ADDRESS

TELEPHONE NUMBER CODE.....NUMBER.....

CELLPHONE NUMBER

FACSIMILE NUMBER CODE NUMBER.....

VAT REGISTRATION NUMBER

HAS A VALID ORIGINAL TAX CLEARANCE CERTIFICATE BEEN ATTACHED (MBD 2)? YES/NO
(if no – please complete the following)
Income Tax Reference number:
TACC Pin

ARE YOU THE ACCREDITED REPRESENTATIVE IN SOUTH AFRICA FOR THE SERVICES OFFERED BY YOU? YES/NO/NOT APPLICABLE
(IF YES ENCLOSE PROOF)

SIGNATURE OF BIDDER

DATE

CAPACITY UNDER WHICH THIS BID IS SIGNED

TOTAL BID PRICE:..... NUMBER OF ITEMS:.....

ANY ENQUIRIES REGARDING THE BIDDING PROCEDURE MAY BE DIRECTED TO:

Municipality: Amajuba District Municipality

Finance Department: Nokwazi Nzimande
Telephone: 034 329 7200
Fax: 086 690 4133

ANY ENQUIRIES REGARDING TECHNICAL INFORMATION MAY BE DIRECTED TO:

Contact Person: Mthembeni Jiyane
Telephone: 034 329 7200
Fax: 0343143785

TAX CLEARANCE CERTIFICATE REQUIREMENTS

It is a condition of bid that the taxes of the successful bidder must be in order, or that satisfactory arrangements have been made with South African Revenue Service (SARS) to meet the bidder's tax obligations.

- 1 In order to meet this requirement bidders are required to complete in full the attached form TCC 001 "Application for a Tax Clearance Certificate" and submit it to any SARS branch office nationally. The Tax Clearance Certificate Requirements are also applicable to foreign bidders / individuals who wish to submit bids.
- 2 SARS will then furnish the bidder with a Tax Clearance Certificate that will be valid for a period of 1 (one) year from the date of approval.
- 3 The original Tax Clearance Certificate must be submitted together with the bid. Failure to submit the original and valid Tax Clearance Certificate will result in the invalidation of the bid. Certified copies of the Tax Clearance Certificate will not be acceptable.
- 4 In bids where Consortia / Joint Ventures / Sub-contractors are involved, each party must submit a separate Tax Clearance Certificate.
- 5 Copies of the TCC 001 "Application for a Tax Clearance Certificate" form are available from any SARS branch office nationally or on the website www.sars.gov.za.
- 6 Applications for the Tax Clearance Certificates may also be made via eFiling. In order to use this provision, taxpayers will need to register with SARS as eFilers through the website www.sars.gov.za.

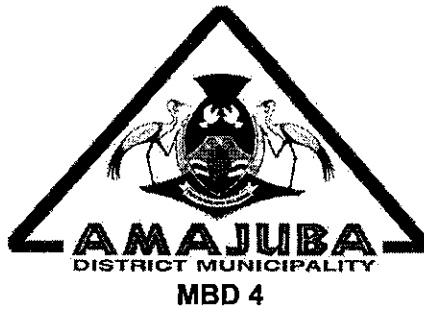

DECLARATION OF INTEREST

1. No bid will be accepted from persons in the service of the state¹.
2. Any person, having a kinship with persons in the service of the state, including a blood relationship, may make an offer or offers in terms of this invitation to bid. In view of possible allegations of favouritism, should the resulting bid, or part thereof, be awarded to persons connected with or related to persons in service of the state, it is required that the bidder or their authorised representative declare their position in relation to the evaluating/adjudicating authority.
- 3 **In order to give effect to the above, the following questionnaire must be completed and submitted with the bid.**

- 3.1 Full Name of bidder or his or her representative:.....
- 3.2 Identity Number:
- 3.3 Position occupied in the Company (director, trustee, shareholder²):.....
- 3.4 Company Registration Number:
- 3.5 Tax Reference Number:.....
- 3.6 VAT Registration Number:
- 3.7 The names of all directors / trustees / shareholders members, their individual identity numbers and state employee numbers must be indicated in paragraph 4 below.

(Please Tick /Mark the correct option in the following questions)

- 3.8 Are you presently in the service of the state? **YES / NO**
- 3.8.1 If yes, furnish particulars.

¹MSCM Regulations: "in the service of the state" means to be –

- (a) a member of –
 - (i) any municipal council;
 - (ii) any provincial legislature; or
 - (iii) the national Assembly or the national Council of provinces;
- (b) a member of the board of directors of any municipal entity;
- (c) an official of any municipality or municipal entity;
- (d) an employee of any national or provincial department, national or provincial public entity or constitutional institution within the meaning of the Public Finance Management Act, 1999 (Act No.1 of 1999);
- (e) a member of the accounting authority of any national or provincial public entity; or
- (f) an employee of Parliament or a provincial legislature.

² Shareholder" means a person who owns shares in the company and is actively involved in the management of the company or business and exercises control over the company.

3.9 Have you been in the service of the state for the past twelve months? **YES / NO**

3.9.1 If yes, furnish particulars.....

.....

3.10 Do you have any relationship (family, friend, other) with persons in the service of the state and who may be involved with the evaluation and or adjudication of this bid? **YES / NO**

3.10.1 If yes, furnish particulars.

.....
.....

3.11 Are you, aware of any relationship (family, friend, other) between any other bidder and any persons in the service of the state who may be involved with the evaluation and or adjudication of this bid? **YES / NO**

3.11.1 If yes, furnish particulars

.....
.....

3.12 Are any of the company's directors, trustees, managers, principle shareholders or stakeholders in service of the state? **YES / NO**

3.12.1 If yes, furnish particulars.

.....
.....

3.13 Are any spouse, child or parent of the company's directors trustees, managers, principle shareholders or stakeholders in service of the state? **YES / NO**

3.13.1 If yes, furnish particulars.

.....
.....

3.14 Do you or any of the directors, trustees, managers, principle shareholders, or stakeholders of this company have any interest in any other related companies or business whether or not they are bidding for this contract. **YES / NO**

3.14.1 If yes, furnish particulars:

.....
.....

4. Full details of directors / trustees / members / shareholders.

Full Name	Identity Number	State Employee Number

.....
Signature

.....
Date

.....
Capacity

.....
Name of Bidder

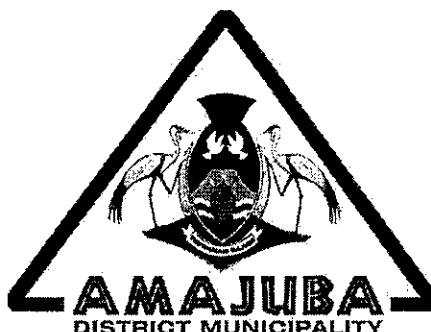

MBD 6.1

PREFERENCE POINTS CLAIM FORM IN TERMS OF THE PREFERENTIAL PROCUREMENT REGULATIONS 2001

PURCHASES

This preference form must form part of all bids invited. It contains general information and serves as a claim form for preference points for Broad-Based Black Economic Empowerment (B-BBEE) Status Level of Contribution

NB: BEFORE COMPLETING THIS FORM, BIDDERS MUST STUDY THE GENERAL CONDITIONS, DEFINITIONS AND DIRECTIVES APPLICABLE IN RESPECT OF B-BBEE, AS PRESCRIBED IN THE PREFERENTIAL PROCUREMENT REGULATIONS, 2011.

1. GENERAL CONDITIONS

1.1 The following preference point systems are applicable to all bids:

- the 80/20 system for requirements with a Rand value up to R1 000 000; and

1.2 The value of this bid is estimated not to exceed R1 000 000 and therefore the 80/20 system shall be applicable.

1.3 Preference points for this bid shall be awarded for:

- (a) Price; and
- (b) B-BBEE Status Level of Contribution

1.3.1 The maximum points for this bid are allocated as follows:

	POINTS
1.3.1.1 PRICE	80
1.3.1.2 B-BBEE STATUS LEVEL OF CONTRIBUTION	20

Total points for Price and B-BBEE must not exceed 100

Separate Preference Points Claim Forms will be used for the promotion of the specific goals for which points have been allocated in paragraph 1.3.1.2 (b) above.

1.4 Failure on the part of a bidder to fill in and/or to sign this form and submit a B-BBEE Verification

Certificate from a Verification Agency accredited by the South African Accreditation System (SANAS) or a Registered Auditor approved by the Independent Regulatory Board of Auditors (IRBA) or an Accounting Officer as contemplated in the Close Corporation Act (CCA) together with the bid, will be interpreted to mean that preference points for B-BBEE status level of contribution are not claimed.

- 1.5. The purchaser reserves the right to require of a bidder, either before a bid is adjudicated or at any time subsequently, to substantiate any claim in regard to preferences, in any manner required by the purchaser.

2.

DEFINITIONS

- 2.1.1 **“all applicable taxes”** includes value-added tax, pay as you earn, income tax, unemployment insurance fund contributions and skills development levies;
- 2.2 **“B-BBEE”** means broad-based black economic empowerment as defined in section 1 of the Broad-Based Black Economic Empowerment Act;
- 2.3 **“B-BBEE status level of contributor”** means the B-BBEE status received by a measured entity based on its overall performance using the relevant scorecard contained in the Codes of Good Practice on Black Economic Empowerment, issued in terms of section 9(1) of the Broad-Based Black Economic Empowerment Act;
- 2.4 **“bid”** means a written offer in a prescribed or stipulated form in response to an invitation by an organ of state for the provision of services, works or goods, through price quotations, advertised competitive bidding processes or proposals;
- 2.5 **“Broad-Based Black Economic Empowerment Act”** means the Broad-Based Black Economic Empowerment Act, 2003 (Act No. 53 of 2003);
- 2.6 **“comparative price”** means the price after the factors of a non-firm price and all unconditional discounts that can be utilized have been taken into consideration;
- 2.7 **“consortium or joint venture”** means an association of persons for the purpose of combining their expertise, property, capital, efforts, skill and knowledge in an activity for the execution of a contract;
- 2.8 **“contract”** means the agreement that results from the acceptance of a bid by an organ of state;
- 2.9 **“EME”** means any enterprise with an annual total revenue of R5 million or less .
- 2.10 **“Firm price”** means the price that is only subject to adjustments in accordance with the actual increase or decrease resulting from the change, imposition, or abolition of customs or excise duty and any other duty, levy, or tax, which, in terms of the law or regulation, is binding on the contractor and demonstrably has an influence on the price of any supplies, or the rendering costs of any service, for the execution of the contract;
- 2.11 **“functionality”** means the measurement according to predetermined norms, as set out in the bid documents, of a service or commodity that is designed to be practical and useful, working or operating, taking into account, among other factors, the quality, reliability, viability and durability of a service and the technical capacity and ability of a bidder;
- 2.12 **“non-firm prices”** means all prices other than “firm” prices;
- 2.13 **“person”** includes a juristic person;
- 2.14 **“rand value”** means the total estimated value of a contract in South African currency, calculated at the time of bid invitations, and includes all applicable taxes and excise duties;
- 2.15 **“sub-contract”** means the primary contractor's assigning, leasing, making out work to, or employing, another person to support such primary contractor in the execution of part of a project in terms of the contract;

- 2.16 “**total revenue**” bears the same meaning assigned to this expression in the Codes of Good Practice on Black Economic Empowerment, issued in terms of section 9(1) of the Broad-Based Black Economic Empowerment Act and promulgated in the *Government Gazette* on 9 February 2007;
- 2.17 “**trust**” means the arrangement through which the property of one person is made over or bequeathed to a trustee to administer such property for the benefit of another person; and
- 2.18 “**trustee**” means any person, including the founder of a trust, to whom property is bequeathed in order for such property to be administered for the benefit of another person.

3. ADJUDICATION USING A POINT SYSTEM

- 3.1 The bidder obtaining the highest number of total points will be awarded the contract.
- 3.2 Preference points shall be calculated after prices have been brought to a comparative basis taking into account all factors of non-firm prices and all unconditional discounts;
- 3.3 Points scored must be rounded off to the nearest 2 decimal places.
- 3.4 In the event that two or more bids have scored equal total points, the successful bid must be the one scoring the highest number of preference points for B-BBEE.
- 3.5 However, when functionality is part of the evaluation process and two or more bids have scored equal points including equal preference points for B-BBEE, the successful bid must be the one scoring the highest score for functionality.
- 3.6 Should two or more bids be equal in all respects, the award shall be decided by the drawing of lots.

4. POINTS AWARDED FOR PRICE

4.1 THE 80/20 PREFERENCE POINT SYSTEMS

A maximum of 90 points is allocated for price on the following basis:

80/20

$$P_s = 80 \left(1 - \frac{P_t - P_{\min}}{P_{\min}} \right)$$

Where

P_s = Points scored for comparative price of bid under consideration

P_t = Comparative price of bid under consideration

P_{\min} = Comparative price of lowest acceptable bid

5. Points awarded for B-BBEE Status Level of Contribution

- 5.1 In terms of Regulation 5 (2) and 6 (2) of the Preferential Procurement Regulations, preference points must be awarded to a bidder for attaining the B-BBEE status level of contribution in accordance with the table below:

B-BBEE Status Level of Contributor	Number of points (80/20 system)
1	20
2	18
3	16
4	12
5	8
6	6
7	4
8	2
Non-compliant contributor	0

- 5.2 Bidders who qualify as EMEs in terms of the B-BBEE Act must submit a certificate issued by an Accounting Officer as contemplated in the CCA or a Verification Agency accredited by SANAS or a Registered Auditor. Registered auditors do not need to meet the prerequisite for IRBA's approval for the purpose of conducting verification and issuing EMEs with B-BBEE Status Level Certificates.
- 5.3 Bidders other than EMEs must submit their original and valid B-BBEE status level verification certificate or a certified copy thereof, substantiating their B-BBEE rating issued by a Registered Auditor approved by IRBA or a Verification Agency accredited by SANAS.
- 5.4 A trust, consortium or joint venture, will qualify for points for their B-BBEE status level as a legal entity, provided that the entity submits their B-BBEE status level certificate.
- 5.5 A trust, consortium or joint venture will qualify for points for their B-BBEE status level as an unincorporated entity, provided that the entity submits their consolidated B-BBEE scorecard as if they were a group structure and that such a consolidated B-BBEE scorecard is prepared for every separate bid.
- 5.6 Tertiary institutions and public entities will be required to submit their B-BBEE status level certificates in terms of the specialized scorecard contained in the B-BBEE Codes of Good Practice.
- 5.7 A person will not be awarded points for B-BBEE status level if it is indicated in the bid documents that such a bidder intends sub-contracting more than 25% of the value of the contract to any other enterprise that does not qualify for at least the points that such a bidder qualifies for, unless the intended sub-contractor is an EME that has the capability and ability to execute the sub-contract.
- 5.8 A person awarded a contract may not sub-contract more than 25% of the value of the contract to any other enterprise that does not have an equal or higher B-BBEE status level than the person concerned, unless the contract is sub-contracted to an EME that has the capability and ability to execute the sub-contract.

6. BID DECLARATION

- 6.1 Bidders who claim points in respect of B-BBEE Status Level of Contribution must complete the following:

7. B-BBEE STATUS LEVEL OF CONTRIBUTION CLAIMED IN TERMS OF PARAGRAPHS 1.3.1.2 AND 5.1

7.1 B-BBEE Status Level of Contribution: =(maximum of 20 points)

(Points claimed in respect of paragraph 7.1 must be in accordance with the table reflected in paragraph 5.1 and must be substantiated by means of a B-BBEE certificate issued by a Verification Agency accredited by SANAS or a Registered Auditor approved by IRBA or an Accounting Officer as contemplated in the CCA).

8 SUB-CONTRACTING

8.1 Will any portion of the contract be sub-contracted? YES / NO (delete which is not applicable)

8.1.1 If yes, indicate:

- (i) what percentage of the contract will be subcontracted?%
- (ii) the name of the sub-contractor?
- (iii) the B-BBEE status level of the sub-contractor?
- (iv) whether the sub-contractor is an EME? YES / NO (delete which is not applicable)

9 DECLARATION WITH REGARD TO COMPANY/FIRM

9.1 Name of company/firm :

9.2 VAT registration number :

9.3 Company registration number :

9.4 TYPE OF COMPANY/ FIRM

- Partnership/Joint Venture / Consortium
- One person business/sole propriety
- Close corporation
- Company
- (Pty) Limited

[TICK APPLICABLE BOX]

9.5 DESCRIBE PRINCIPAL BUSINESS ACTIVITIES

.....
.....
.....

9.6 COMPANY CLASSIFICATION

- Manufacturer
- Supplier
- Professional service provider
- Other service providers, e.g. transporter, etc.

[TICK APPLICABLE BOX]

9.7 Total number of years the company/firm has been in business?

9.8 I/we, the undersigned, who is / are duly authorised to do so on behalf of the company/firm, certify

that the points claimed, based on the B-BBE status level of contribution indicated in paragraph 7 of the foregoing certificate, qualifies the company/ firm for the preference(s) shown and I / we acknowledge that:

- (i) The information furnished is true and correct;
- (ii) The preference points claimed are in accordance with the General Conditions as indicated in paragraph 1 of this form.
- (iii) In the event of a contract being awarded as a result of points claimed as shown in paragraph 7, the contractor may be required to furnish documentary proof to the satisfaction of the purchaser that the claims are correct;
- (iv) If the B-BBEE status level of contribution has been claimed or obtained on a fraudulent basis or any of the conditions of contract have not been fulfilled, the purchaser may, in addition to any other remedy it may have –
 - (a) disqualify the person from the bidding process;
 - (b) recover costs, losses or damages it has incurred or suffered as a result of that person's conduct;
 - (c) cancel the contract and claim any damages which it has suffered as a result of having to make less favourable arrangements due to such cancellation;
 - (d) restrict the bidder or contractor, its shareholders and directors, or only the shareholders and directors who acted on a fraudulent basis, from obtaining business from any organ of state for a period not exceeding 10 years, after the audi alteram partem (hear the other side) rule has been applied; and
 - (e) forward the matter for criminal prosecution

WITNESSES:

1.

2.

<p>..... SIGNATURE(S) OF BIDDER(S)</p>
--

DATE:.....

ADDRESS:.....

.....

.....



DECLARATION OF BIDDER'S PAST SUPPLY CHAIN MANAGEMENT PRACTICES

- 1 This Municipal Bidding Document must form part of all bids invited.
- 2 It serves as a declaration to be used by municipalities and municipal entities in ensuring that when goods and services are being procured, all reasonable steps are taken to combat the abuse of the supply chain management system.
- 3 The bid of any bidder may be rejected if that bidder, or any of its directors have:
 - a. abused the municipality's / municipal entity's supply chain management system or committed any improper conduct in relation to such system;
 - b. been convicted for fraud or corruption during the past five years;
 - c. willfully neglected, reneged on or failed to comply with any government, municipal or other public sector contract during the past five years; or
 - d. been listed in the Register for Tender Defaulters in terms of section 29 of the Prevention and Combating of Corrupt Activities Act (No 12 of 2004).
- 4 In order to give effect to the above, the following questionnaire must be completed and submitted with the bid.

Item	Question	Yes	No
4.1	<p>Is the bidder or any of its directors listed on the National Treasury's database as a company or person prohibited from doing business with the public sector?</p> <p>(Companies or persons who are listed on this database were informed in writing of this restriction by the National Treasury after the <i>audi alteram partem</i> rule was applied).</p>	Yes <input type="checkbox"/>	No <input type="checkbox"/>

4.1.1	If so, furnish particulars:		
4.2	Is the bidder or any of its directors listed on the Register for Tender Defaulters in terms of section 29 of the Prevention and Combating of Corrupt Activities Act (No 12 of 2004)? (To access this Register enter the National Treasury's website, www.treasury.gov.za , click on the icon "Register for Tender Defaulters" or submit your written request for a hard copy of the Register to facsimile number (012) 3265445).	Yes <input type="checkbox"/>	No <input type="checkbox"/>
4.2.1	If so, furnish particulars:		
4.3	Was the bidder or any of its directors convicted by a court of law (including a court of law outside the Republic of South Africa) for fraud or corruption during the past five years?	Yes <input type="checkbox"/>	No <input type="checkbox"/>
4.3.1	If so, furnish particulars:		
Item	Question	Yes	No
4.4	Does the bidder or any of its directors owe any municipal rates and taxes or municipal charges to the municipality / municipal entity, or to any other municipality / municipal entity, that is in arrears for more than three months?	Yes <input type="checkbox"/>	No <input type="checkbox"/>
4.4.1	If so, furnish particulars:		
4.5	Was any contract between the bidder and the municipality / municipal entity or any other organ of state terminated during the past five years on account of failure to perform on or comply with the contract?	Yes <input type="checkbox"/>	No <input type="checkbox"/>
4.7.1	If so, furnish particulars:		

CERTIFICATION

**I, THE UNDERSIGNED (FULL NAME)
CERTIFY THAT THE INFORMATION FURNISHED ON THIS
DECLARATION FORM TRUE AND CORRECT.**

**I ACCEPT THAT, IN ADDITION TO CANCELLATION OF A CONTRACT, ACTION
MAY BE TAKEN AGAINST ME SHOULD THIS DECLARATION PROVE TO BE
FALSE.**

.....
Signature

.....
Date

.....
Position

.....
Name of Bidder

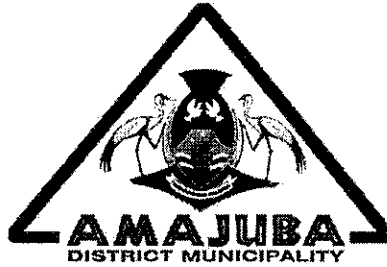

MBD 9

CERTIFICATE OF INDEPENDENT BID DETERMINATION

- 1 This Municipal Bidding Document (MBD) must form part of all bids¹ invited.
- 2 Section 4 (1) (b) (iii) of the Competition Act No. 89 of 1998, as amended, prohibits an agreement between, or concerted practice by, firms, or a decision by an association of firms, if it is between parties in a horizontal relationship and if it involves collusive bidding (or bid rigging).² Collusive bidding is a *pe se* prohibition meaning that it cannot be justified under any grounds.
- 3 Municipal Supply Regulation 38 (1) prescribes that a supply chain management policy must provide measures for the combating of abuse of the supply chain management system, and must enable the accounting officer, among others, to:
 - a. take all reasonable steps to prevent such abuse;
 - b. reject the bid of any bidder if that bidder or any of its directors has abused the supply chain management system of the municipality or municipal entity or has committed any improper conduct in relation to such system; and
 - c. cancel a contract awarded to a person if the person committed any corrupt or fraudulent act during the bidding process or the execution of the contract.
- 4 This MBD serves as a certificate of declaration that would be used by institutions to ensure that, when bids are considered, reasonable steps are taken to prevent any form of bid-rigging.
- 5 In order to give effect to the above, the attached Certificate of Bid Determination (MBD
- 9) must be completed and submitted with the bid:

¹ Includes price quotations, advertised competitive bids, limited bids and proposals.

² Bid rigging (or collusive bidding) occurs when businesses, that would otherwise be expected to compete, secretly conspire to raise prices or lower the quality of goods and / or services for purchasers who wish to acquire goods and / or services through a bidding process. Bid rigging is, therefore, an agreement between competitors not to compete.

CERTIFICATE OF INDEPENDENT BID DETERMINATION

I, the undersigned, in submitting the accompanying bid:

**T2016/13: SUPPLY AND ERECTION OF SECURITY FENCING IN KWAPOLITENI
WATER POINT, DANNHAUSER CBD RESERVOIR AND INVERNESS WATER
POINT**

(Bid Number and Description)

in response to the invitation for the bid made by:

AMAJUBA DISTRICT MUNICIPALITY

do hereby make the following statements that I certify to be true and complete in every respect:

I certify, on behalf

of: _____ that:

(Name of Bidder)

1. I have read and I understand the contents of this Certificate;
2. I understand that the accompanying bid will be disqualified if this Certificate is found not to be true and complete in every respect;
3. I am authorized by the bidder to sign this Certificate, and to submit the accompanying bid, on behalf of the bidder;
4. Each person whose signature appears on the accompanying bid has been authorized by the bidder to determine the terms of, and to sign, the bid, on behalf of the bidder;
5. For the purposes of this Certificate and the accompanying bid, I understand that the word "competitor" shall include any individual or organization, other than the bidder, whether or not affiliated with the bidder, who:
 - (a) has been requested to submit a bid in response to this bid invitation;
 - (b) could potentially submit a bid in response to this bid invitation, based on their qualifications, abilities or experience; and
 - (c) provides the same goods and services as the bidder and/or is in the same line of business as the bidder

MBD 9

6. The bidder has arrived at the accompanying bid independently from, and without consultation, communication, agreement or arrangement with any competitor. However communication between partners in a joint venture or consortium³ will not be construed as collusive bidding.
7. In particular, without limiting the generality of paragraphs 6 above, there has been no consultation, communication, agreement or arrangement with any competitor regarding:
 - (a) prices;
 - (b) geographical area where product or service will be rendered (market allocation)
 - (c) methods, factors or formulas used to calculate prices;
 - (d) the intention or decision to submit or not to submit, a bid;
 - (e) the submission of a bid which does not meet the specifications and conditions of the bid; or
 - (f) bidding with the intention not to win the bid.
8. In addition, there have been no consultations, communications, agreements or arrangements with any competitor regarding the quality, quantity, specifications and conditions or delivery particulars of the products or services to which this bid invitation relates.
9. The terms of the accompanying bid have not been, and will not be, disclosed by the bidder, directly or indirectly, to any competitor, prior to the date and time of the official bid opening or of the awarding of the contract.

³ **Joint venture or Consortium means an association of persons for the purpose of combining their expertise, property, capital, efforts, skill and knowledge in an activity for the execution of a contract.**

MBD 9

10. I am aware that, in addition and without prejudice to any other remedy provided to combat any restrictive practices related to bids and contracts, bids that are suspicious will be reported to the Competition Commission for investigation and possible imposition of administrative penalties in terms of section 59 of the Competition Act No. 89 of 1998 and or may be reported to the National Prosecuting Authority (NPA) for criminal investigation and or may be restricted from conducting business with the public sector for a period not exceeding ten (10) years in terms of the Prevention and Combating of Corrupt Activities Act No. 12 of 2004 or any other applicable legislation.

.....
Signature **Date**

.....
Position

Name of Bidder